

# EVAPORATOR PRESSURE REGULATING VALVES

for Evaporator Temperature Control



SORIT-12



ORIT-6

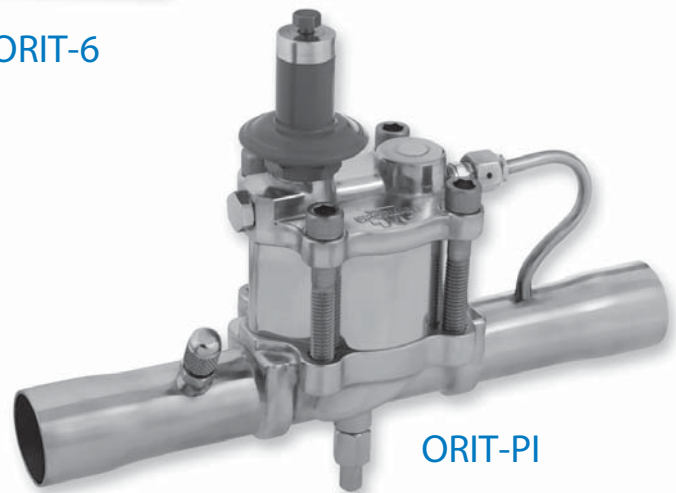

ORIT-PI

ORIT-6



ORIT-15

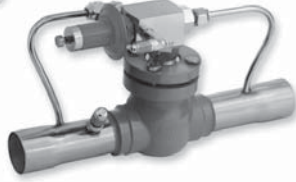

ORIT-PI

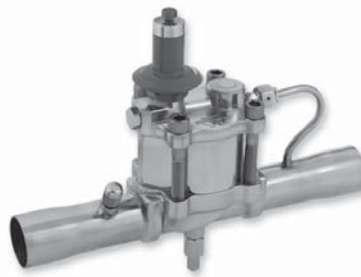

SORIT-12



## Table of Contents

Evaporator Pressure Regulation .....	3
Application .....	3
Valve Operation.....	5
Direct Acting Valves – ORIT-6 & ORIT-10.....	5
Pilot Operated Valves – (S)ORIT-12, (S)ORIT-15, & (S)ORIT-20.....	5
Pilot Operated Valves – (S)ORIT-PI-2, -3, -4, & -5.....	6
FactoryValve Settings .....	8
Selection Procedures.....	8
Specifications & Nomenclature .....	10
Direct Acting Valves – ORIT-6 & ORIT-10.....	10
Pilot Operated Valves – (S)ORIT-12, (S)ORIT-15, & (S)ORIT-20.....	11
Pilot Operated Valves – (S)ORIT-PI-2, -3, -4, & -5.....	12
Capacity Tables.....	13
Quick Pick Selection Tables .....	14 & 15

FOR USE ON REFRIGERATION and/or AIR CONDITIONING SYSTEMS ONLY  
 Bulletin 90-20, June 2010, supersedes Bulletin 90-20, November 2001, 90-20-1, August 1991,  
 90-20-2, January 1996, and 90-20-2A, January 1999 and all prior publications.

## Evaporator Pressure Regulation

Sporlan Evaporator Pressure Regulating valves (EPRs) are designed to provide an economical means of accurately maintaining evaporator pressure and temperature under varying evaporator loads. The primary function of an EPR is to prevent the evaporator pressure from falling below a predetermined value or setting. A consistent evaporating temperature is maintained at the valve setting as evaporator loads decrease. When the evaporator load increases, the valve Opens on a Rise of Inlet pressure above its setting. Controlling evaporator temperature, by maintaining the saturation pressure of the refrigerant in the evaporator, provides more consistent evaporator temperature than a conventional thermostat or suction pressure cut-out control.

These methods of control allow the evaporator pressure to decrease as the load drops off; lowering the evaporator temperature and decreasing evaporator performance, while increasing evaporator frost build up.

Sporlan offers three types of evaporator pressure regulating valves, covering applications from small spot coolers to large multiplex supermarket systems. The ORIT-6 and ORIT-10 EPRs are direct acting and offered with standard adjustment ranges and fitting options. The (S)ORIT and (S)ORIT-PI pilot operated EPRs provide more capacity at lower pressure drops, and offer additional features including solenoid shut off for defrost applications.

## Application

Sporlan evaporator pressure regulating valves are used in many applications to provide:

- Consistent evaporator pressures and temperatures (during decreasing load conditions) for excellent system temperature control.
- Allow multiple evaporator systems to operate at different temperatures when piped to a common suction group.

These applications are categorized as single evaporator or multiple evaporator systems.

### Single evaporator/single compressor systems:

There are many single evaporator systems which utilize EPRs for precise evaporator temperature control (see Figure 1). However, there are several factors to consider. Proper valve selection is critical. Since pressure drop in the suction line is lost efficiency, EPRs are commonly oversized to reduce suction line pressure drop. Single evaporator systems can allow as little as 2 psi drop across direct acting EPRs (0.5 psi

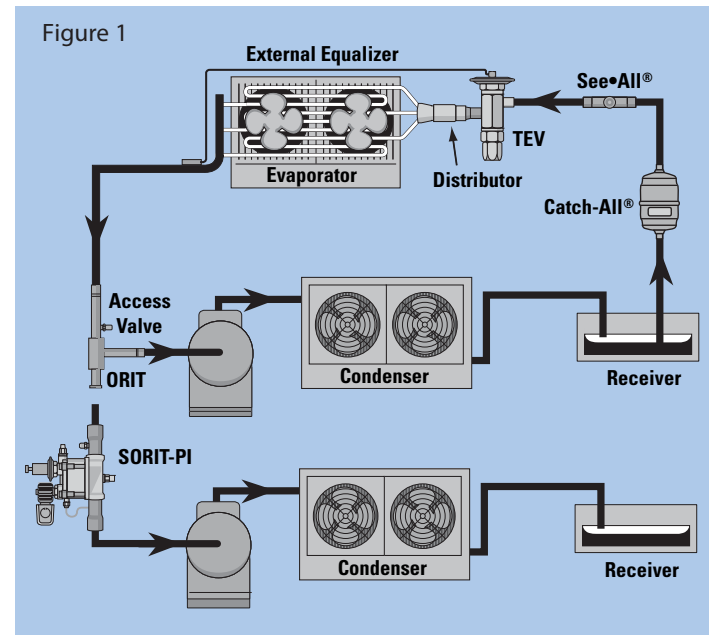

drop across SORIT and 1.0 psi drop across SORIT-PI pilot operated EPRs,) and still maintain acceptable control. Severely oversized valves can cause pressure hunting and negatively impact temperature control.

In addition, special consideration must be given to single compressor systems. In these applications the suction pressure can drop to an undesirably low level as the EPR throttles to maintain the evaporator pressure. In these cases, a discharge bypass valve must be used to maintain acceptable compressor suction pressure. These valves are typically piped with the valve outlet feeding the suction line downstream of the EPR. Special considerations must be taken to protect the compressor from overheating when using a discharge bypass valve. These considerations and the application of the discharge bypass valve are discussed further in Sporlan Bulletin 90-40. Bypassed discharge gas can be introduced at the inlet of the evaporator or upstream of the evaporator pressure regulator to maintain a minimum suction pressure. But, the discharge bypass valve must be externally equalized, and the external equalizer connection must be downstream of the evaporator pressure regulator.

### Multiple evaporator systems:

Many supermarket applications use multiple evaporators piped to a common suction header (see Figure 2). These evaporators can be operated at different temperatures for the various products being refrigerated. This is the most common application for pilot operated EPRs. Any group of evaporators where the desired saturation temperature is higher than the saturation temperature corresponding to the common suction pressure will require an EPR. For example, if evaporator A in Figure 2 is designed for  $-10^{\circ}\text{F}$  (24.0 psig for R404A), and evaporator B for  $-20^{\circ}\text{F}$  (16.0 psig), an EPR would be used to maintain evaporator A at the 24.0 psig setting. In addition, if the common suction at

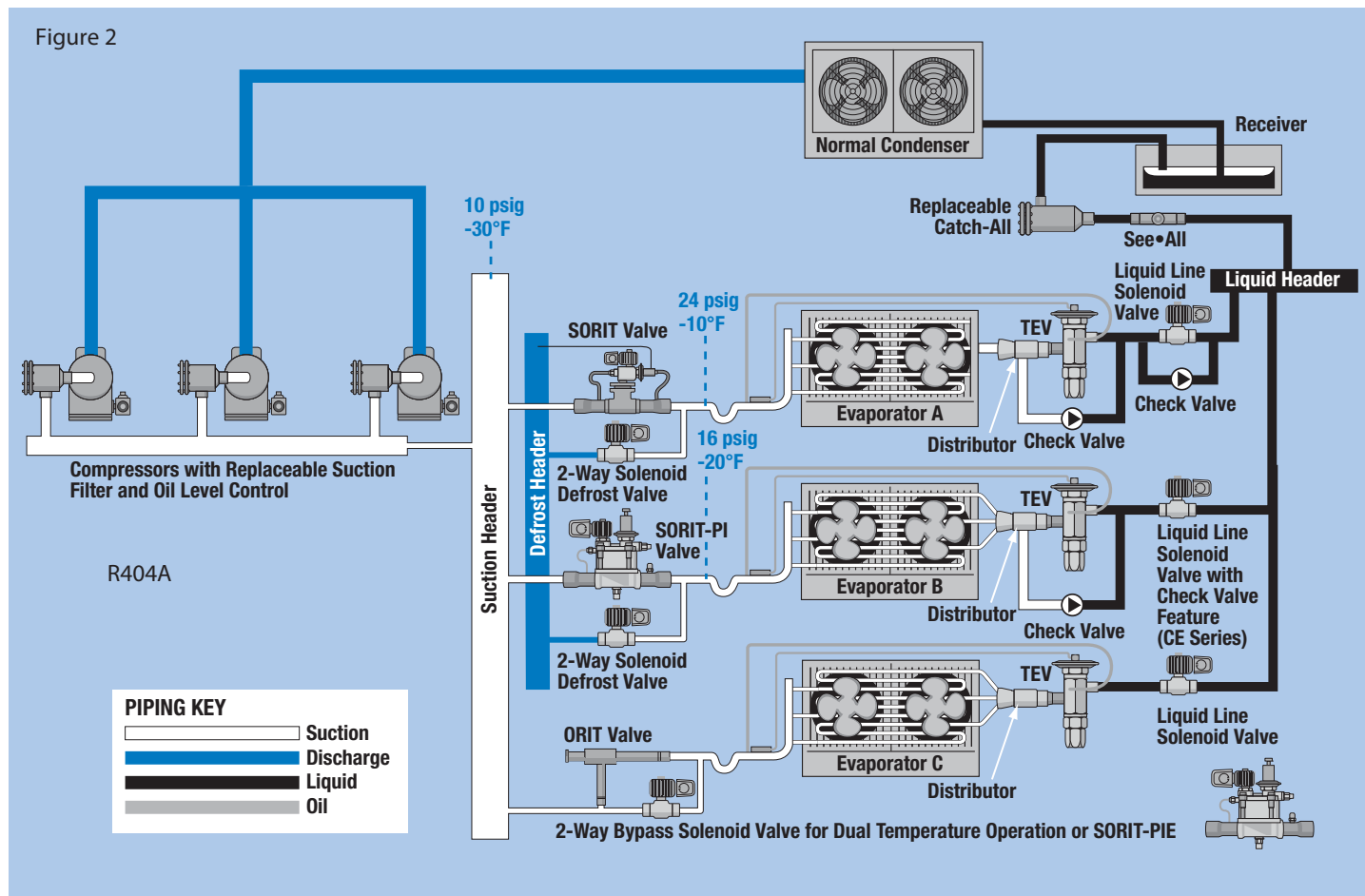

the compressors was set for -30°F (10.0 psig) then an EPR would also be required on evaporator B. In many applications, EPRs are installed with every evaporator group to act as a suction stop solenoid valve for defrost while still maintaining the flexibility to set the evaporator saturation pressure if necessary.

As with the single evaporator applications, proper valve selection will always yield the optimum performance under all operating conditions (See selection procedure for more detail).

#### Loop Systems:

On these systems, the evaporator groups are piped to a common liquid and suction trunk line "looped" throughout the store. EPRs are installed in or near the case on loop systems. Sporlan direct acting ORITs and the internally piloted (S)ORIT-PIs are recommended for loop systems requiring EPRs. Externally piloted (S)ORITs are not recommended, as high pressure vapor is required to operate the valve.

#### Dual Temperature Applications:

Dual temperature applications allow a supermarket to operate a refrigerated display case at either low or medium temperature to meet the promotional needs of the store. Typically a refrigerated display case (or cases) applied in this manner would be piped to the low temperature suction group.

Direct acting ORIT-6 and -10 EPRs are used in these applications with a solenoid valve in parallel (see Evaporator C, Figure 2). If a normally closed solenoid valve is used, energizing the coil will bypass the EPR and allow the case to pull down to the common suction pressure. De-energizing the coil will return control to the EPR. Some applications with ORI-6 or -10s use a normally open solenoid in parallel to allow the system to "fail-safe" in low temperature mode. In these applications energizing the coil will cause the valve to close, diverting refrigerant flow to the EPR. The EPR will then control the evaporator at the higher pressure setting.

Pilot Operated EPRs are wide open in the low temperature operating mode and can be electrically switched to control at the valve set point. The (S)ORIT-PIE internally piloted EPRs are offered with an optional Electric open feature designed specifically for these applications. In addition the (S)ORIT-PIE can be installed at the rack, or in the case, since a high-side pilot connection is not necessary. Operation details of the electric open feature of the (S)ORIT-PIE are covered on Page 7. The (S)ORIT high pressure piloted EPRs can be converted for dual temperature applications by installing an A3/E3 solenoid valve in the high pressure vapor pilot line.

#### Defrost Applications:

Most refrigeration applications require occasional defrosting of the evaporator to maintain proper performance and temperature control of the refrigerated

space. There are several means of defrosting the evaporator including off-time, electric heat, and gas defrost. The SORIT and SORIT-PI EPRs are equipped with a suction stop solenoid feature that will close the valve when de-energized to assist with any of these methods of defrost. In the case of gas defrost, high pressure vapor is usually introduced upstream of the EPR, and the SORIT or SORIT-PI solenoid stop feature is used to prevent the defrost gas from entering the suction line and overheating/overloading the compressors.

Some gas defrost applications require reverse flow through the EPR. The SORIT-PI internally piloted EPRs will allow reverse flow of defrost gas through the valve. This allows the valve to be installed in the refrigerated display case or in the store piping trench on gas defrost systems without additional check valve piping. The SORIT-PI suction stop solenoid coil must be de-energized for proper reverse flow operation.

#### Paralleling Evaporator Pressure Regulators:

If the system capacity is greater than the largest EPR model available for the application, like model and size valves can be applied in parallel. The valve should be selected for half the system capacity to provide the proper selection, and both valves adjusted to control the same setting. This will ensure that the pressure drop across each valve is the same.

#### Piping Suggestions:

The piping schematics used in this bulletin are for illustration purposes only to demonstrate general location of the evaporator pressure regulating valve in the system. Sporlan recommends that recognized piping references be consulted for assistance in piping procedures. Sporlan is not responsible for system design, any damage resulting from faulty system design, or for the misapplication of its products. Sporlan reserves the right to void the product warranty if the product is not applied as described in this bulletin.

#### Refrigerants:

Sporlan evaporator pressure regulating valves can be applied with any of the commonly used CFC, HCFC, and HFC refrigerants. None of the Sporlan EPR products are suitable for R717(Ammonia).

## Valve Operation

Understanding valve operation of Sporlan's different EPR models is critical to ensuring proper product selection for each application. Each model offers unique features that provide distinct benefits for various applications where these products can be used. All Sporlan EPRs are applied at the outlet of the evaporator and control evaporator or valve inlet pressure only.

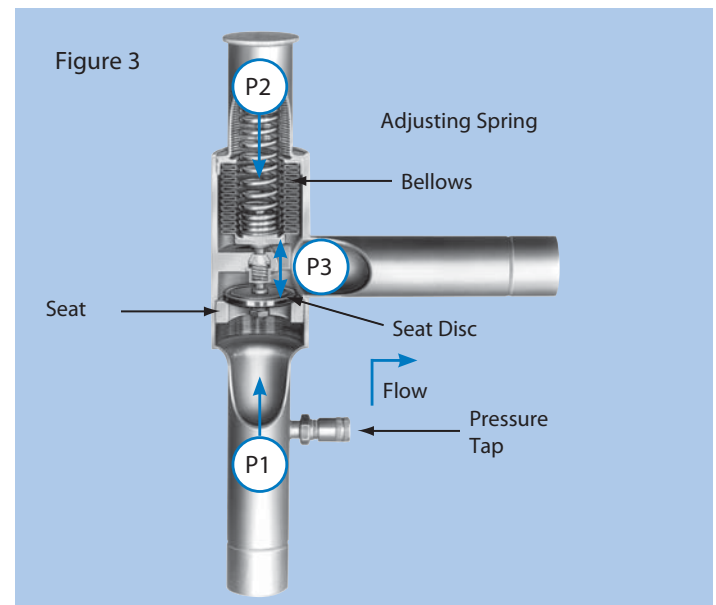

To indicate this trait, the valve nomenclature describes valve operation as Open on Rise of Inlet pressure or ORI.

For pressure regulating valves to modulate closed or open, requires a change in the pressure being regulated by the valve. The amount of change in valve stroke, for a given change in pressure, is the valve gradient. Every valve has a gradient designed to provide the best possible operation. Valve sensitivity or "gain" relates to how the valve reacts with the system and how well it controls the regulated pressure. Valve gain is a function of both the valve gradient and the valve capacity. The more "over-sized" a valve and the "steeper" the gradient, the more sensitive or higher the gain will be, and the more the flow will change with a change in inlet pressure. Generally speaking, a more sensitive valve will provide closer control of the inlet pressure. However, a grossly oversized valve can cause hunting and fluctuating system pressures. Direct acting models require more valve gradient to fully stroke the valve, and are generally more sensitive to over-sizing than the pilot operated models.

Valve setting is defined as the minimum control pressure, or the opening inlet pressure of the valve. Below the setting the valve will close and stop refrigerant flow until the valve setting is reached. As inlet pressure increases above the valve setting, the valve will open at the rate of the valve's gradient, to provide more flow.

#### Direct Acting Valves - ORIT-6 and ORIT-10:

These models control inlet pressure only and have no other optional modes of operation. As illustrated in Figure 3, the outlet pressure (P3) is exerted against both the bellows effective area and the outlet side of the seat disc. Since the effective area of the bellows is equal to the area of the valve port the outlet pressure forces are cancelled and do not affect valve operation. The force created by the valve inlet pressure (P1)

operating on the seat disc across the area of the port, opposes the force exerted by the adjustment spring (P2), and provides the two operating forces for these direct acting evaporator pressure regulating valves. The force exerted by the valve's adjustment spring determines the valve's pressure setting. As the inlet pressure increases above the valve setting, the inlet pressure acting on the seat disc at the port of the valve will overcome the force exerted by the adjustment spring and will cause the valve to open. This allows flow through the valve. Increasing the adjustment spring force will increase the valve setting and the pressure required to open the valve. As evaporator loads drop, and less refrigerant is boiled off in the evaporator, the evaporator pressure will decrease and cause the seat disc to move to a more closed position, until it reaches the valve setting or minimum evaporator pressure. Any decrease in pressure below the setting will cause the valve to close.

Since direct acting valves are set at the minimum evaporator pressure, and require an increase in inlet pressure to open against the valve gradient, Sporlan's direct acting EPRs are rated for capacity at a design evaporator pressure higher than the valve setting (see Selection Procedures for more information).

**Externally Pilot Operated Valves – (S)ORIT-12, -15, and -20:**

**Pressure Regulating Operation:** These pilot operated EPRs use high side pilot pressure to control the main valve piston that regulates upstream/inlet pressure. The high side pressure source allows this valve to be provided normally open. This allows the valve to be operated at minimal pressure drop to ensure maximum capacity by minimizing suction line pressure losses. The high side pressure source must meet the following criteria to ensure optimum performance of the pilot operated pressure regulating valve:

- High pressure supply source to the pilot valve.
- The pilot supply line should be kept as short as possible to minimize refrigerant condensation.
- The high pressure supply source should be at least 50 psi greater than the downstream, or common suction pressure, at the outlet of the pressure regulating valve.
- If used with gas defrost, the pilot supply source must be at the same supply source or higher pressure supply source than the defrost gas.

The pilot valve modulates in response to the upstream, or inlet pressure, as shown in Figure 4. As the inlet or evaporator pressure drops (P1 acting on the underside of the pilot valve diaphragm through the inlet pilot tube connection), the adjustment spring (P2 on top of the pilot valve diaphragm) modulates the pilot port open, and allows high side pressure (P5) to enter the chamber on top of the main valve piston. As soon as the pressure in the chamber (P3) exceeds the evaporator pressure, the main piston begins to move closed against the opening spring (P4). As the valve inlet/evaporator pressure increases under the diaphragm the pilot port will modulate closed, and decrease the flow of high side pressure on top of the piston. This will allow the pressure on the top of the piston to vent to the outlet of the valve through the bleed orifice. Once the pressure approaches the valve inlet pressure the opening spring will open the main port and allow additional flow from the evaporator.

**Defrost Operation:** The SORIT version is equipped with a suction stop feature in the pilot valve. This feature will immediately close the valve for defrost applications. With the pilot solenoid de-energized, as shown in Figure 5, high side pressure is allowed to enter on top of the piston, bypassing the pilot valve port. The high side pressure forces the main piston closed as long as the inlet pressure to the valve does not exceed the pressure of the high side source to the pilot.

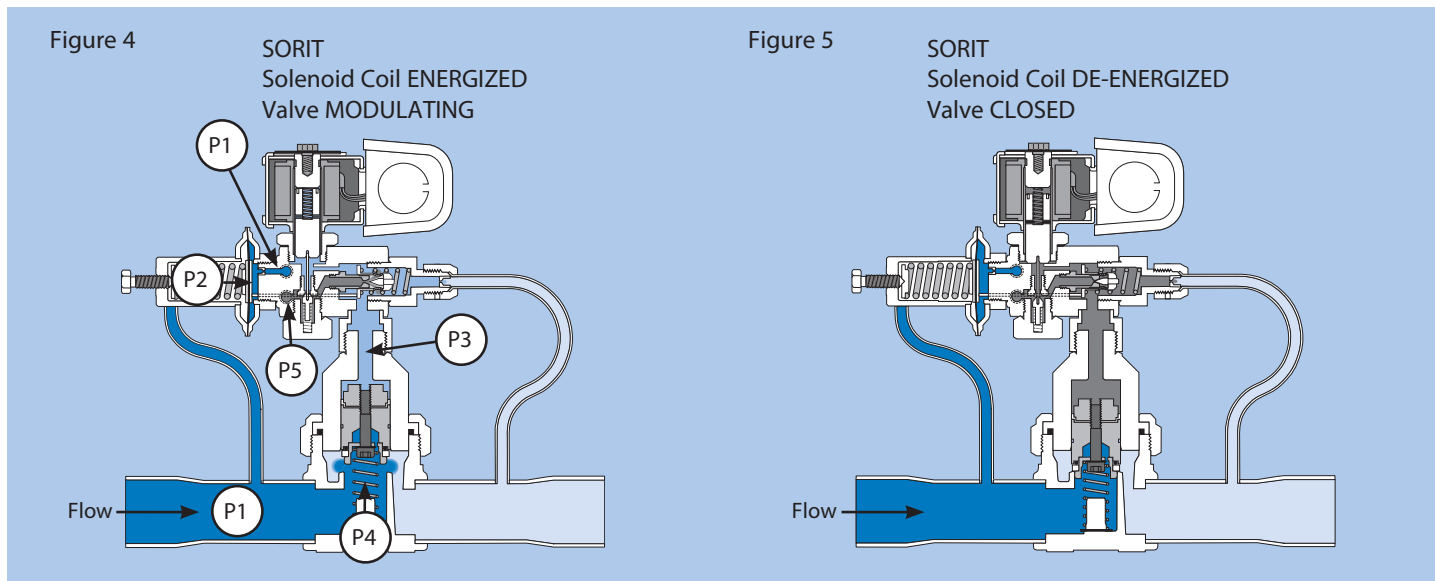

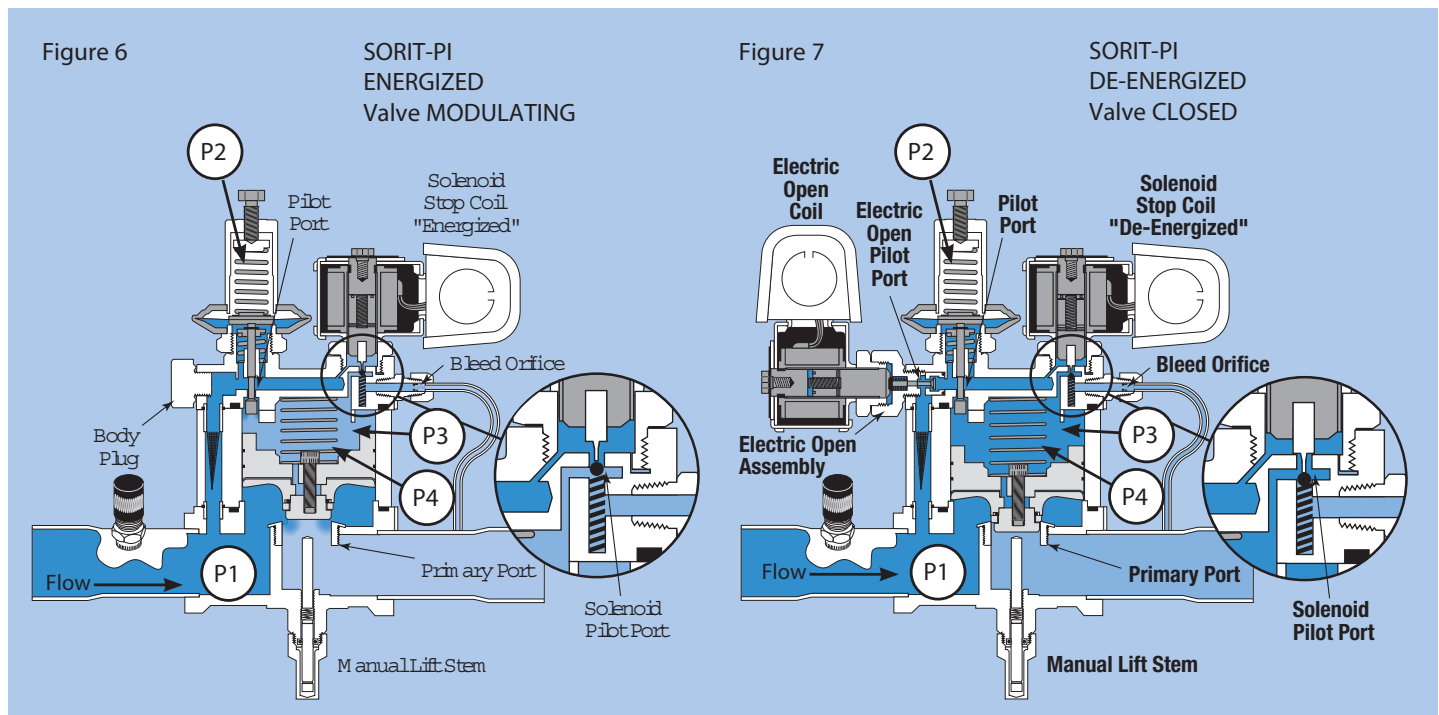

When defrost is terminated, the pilot solenoid coil is energized and the pilot solenoid port is closed. High side pressure on top of the piston is vented to the outlet of the valve through the bleed orifice. Once the pressure approaches the valve setting the valve begins to modulate to control the inlet pressure setting.

Operation Savings: (S)ORIT high side piloted EPRs can provide significant energy savings by reducing suction line pressure drop. Piloting with high side vapor allows a normally open valve design that can be applied at pressure drops less than 0.5 psi. This allows the common suction to run at the highest possible pressure and still maintain the coldest evaporator temperature on the rack. Table 1 shows the percentage of compressor capacity loss due to suction line pressure drop. As shown in the table, this capacity loss increases considerably at lower evaporator temperatures. For example, an R-22 system running at a -25°F common suction would use approximately 3.5% less compressor power with high side piloted EPRs sized at a 0.5 psi drop, when compared to internally piloted EPRs sized for a 1 psi drop.

Table 1

Suction Line Pressure Drop	% of Compressor Capacity Loss due to Pressure Drop		
	R22	R22	R404A
	+10°F / -12°C Evap.	-25°F / -32°C Evap.	-25°F / -32°C Evap.
0	—	—	—
1	2.2	5.6	6.1
2	4.4	12.7	10.4
3	7.1	18.1	15.3
4	9.5	24.2	19.5

Based on compressor capacity curves at 100°F condensing.

**Internally Pilot Operated Valves – (S)ORIT-PI-2, -3, -4, and -5:**

Pressure Regulating Operation: Since these EPRs are Piloted Internally, they do not require a high side pressure source to operate. The valves are operated by the pressure differential across the valve and require a minimum pressure drop of 1 psi to obtain full capacity. The pilot valve modulates in response to the upstream or inlet pressure. The inlet pressure (P1) is transmitted through internal passages to the underside of the pilot valve diaphragm as shown in Figure 6. As the inlet or evaporator pressure drops, the adjustment spring (P2) on top of the pilot valve diaphragm modulates the pilot port open, and allows inlet pressure to enter the chamber on top of the valve piston. As the pressure in the piston chamber (P3) approaches the inlet or evaporator pressure (P1), the closing spring force (P4) causes the valve piston to modulate to a more closed position. With the valve piston further closed an increase in inlet or evaporator pressure (P1) will move the pilot port to a more closed position and allow the piston chamber pressure (P3) to decrease by venting to the outlet of the valve through the bleed orifice. As the piston chamber pressure (P3) decreases, the inlet pressure (P1) will push against the valve piston causing it to modulate open and compress the closing spring.

Defrost Operation: The SORIT-PI version is equipped with a suction stop feature in the pilot that allows the valve to completely close for defrost applications. This is accomplished with a 3-way solenoid operator, date codes 26-02 and after, as shown in Figures 6 and 7. With the pilot solenoid coil de-energized, as shown in Figure 7, inlet pressure (P1) is allowed to enter the piston chamber through the upper solenoid port. At the same time, the lower solenoid port is closed,

preventing flow to the bleed orifice from the piston chamber. The pressure in the piston chamber (P3) plus the closing spring force (P4) will exceed the force of inlet pressure (P1), allowing the valve to close during defrost.

When defrost is terminated, the pilot solenoid coil is energized as shown in Figure 6 and the upper solenoid port is closed and the lower solenoid port is opened. This returns the valve to pressure regulating mode, and the valve opens to allow the evaporator to pull down to the valve setting.

In addition, SORIT-PI or ORIT-PI valves may be applied in the display case or piping trench and can be “reverse-flowed” for gas defrost. See Defrost Applications on page 4.

**Manual Lift Operation:** All (S)ORIT-PI valves are equipped with a manual lift stem that will mechanically open the valve independent of refrigerant flow or operating mode (see Figure 7). Turning the lift stem clockwise will push the main piston open. The lift stem must be fully retracted (turn counterclockwise to stop) to ensure proper operation during other operating modes. The lift stem is typically used to simplify installation and service. This will facilitate nitrogen flow and system evacuation prior to start-up.

**Electric Open Operation:** The (S)ORIT-PI valve can be specified with an optional electric open feature, as shown in Figure 7, for dual temperature applications. See Dual Temperature Applications on Page 4. The body plug in the (S)ORIT-PI pilot valve shown in Figure 6 is replaced with a solenoid operator that when energized will prevent the flow of inlet pressure to the pilot (if using the electric open feature with a SORIT-PI valve it is also necessary to simultaneously energize the defrost solenoid operator to ensure proper operation). The pressure above the piston will vent to the valve outlet through the bleed orifice allowing the valve piston to fully open. When the electric open solenoid is de-energized, the solenoid port will open and allow flow of inlet pressure to the pilot valve, returning the valve to pressure regulating operation.

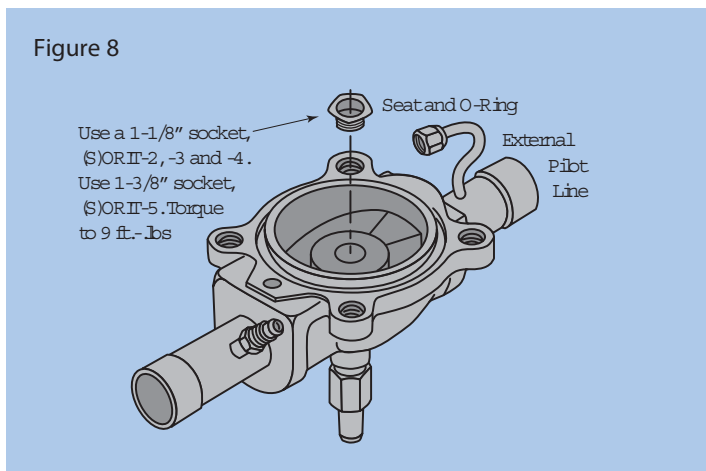

**Interchangeable Valve Seats:** As a new feature, date code 26-02 and after, the (S)ORIT-PI EPRs have been redesigned to include a threaded port and interchangeable valve seat. This new design provides an easy means of changing valve capacity/port size without having to replace the valve body. Refer to Figure 8 for installation and removal method, and Table 2 for available sizing kits.

### Selection Procedures

Proper specification of a Sporlan EPR involves selecting a model type based on desired features, options, application, and the proper valve sizing to match the evaporator(s) design capacity. The following information is required to properly size an evaporator pressure regulating valve:

1. Refrigerant.
2. Minimum evaporator temperature or valve setting (for direct acting ORI(T)-6 and -10 models only).
3. Evaporator design temperature.
4. Design common suction pressure (multiple evaporator systems) or available pressure drop across valve at evaporator design capacity (single evaporator systems).
5. Evaporator(s) design capacity (Tons or Btu/hr).
6. Liquid Temperature.

Table 2

Current Valve Size	Desired Valve Size	Remove Existing Seat	Install New Seat	Piston Assembly and Seat Kit
(S)ORIT-PI-2	(S)ORIT-PI-3	Yes	Yes	SK-PI-4 a 3
(S)ORIT-PI-2	(S)ORIT-PI-4	Yes	NO	SK-PI-4 *
(S)ORIT-PI-3	(S)ORIT-PI-2	Yes	Yes	SK-PI-4 a 2
(S)ORIT-PI-3	(S)ORIT-PI-4	Yes	NO	SK-PI-4 *
(S)ORIT-PI-4	(S)ORIT-PI-2	N/A	Yes	SK-PI-4 a 2
(S)ORIT-PI-4	(S)ORIT-PI-3	N/A	Yes	SK-PI-4 a 3
(S)ORIT-PI-5	(S)ORIT-PI-3	N/A	Yes	SK-PI-5 a 3
(S)ORIT-PI-5	(S)ORIT-PI-4	N/A	Yes	SK-PI-5 a 4

\* Seat not supplied or required.

With these application conditions valve selections can be made directly from the capacity tables on Page 13 for any application. Special considerations for selecting direct acting models are covered on Page 9. Capacity tables on Pages 14 and 15 are quick pick selection tables for pilot operated EPRs used on supermarket rack applications (multiple evaporator systems). The available pressure drop, on supermarket rack applications, is a function of the system design and the difference between the saturated pressure at the evaporator design temperature (circuit temperature) – the design common suction pressure (header temperature). This is referred



to as the “natural” pressure drop for these systems. The Quick Pick Selection tables on Pages 14 and 15, allow easy selection of a pilot operated EPR, based on the applicable conditions and considers the “natural” pressure drop for the system design criteria listed.

#### Direct Acting ORI(T)-6 & ORI(T)-10 Selection:

As described in Valve Operation-Direct Acting Valves – ORIT-6 & ORIT-10, Page 5, the reported valve capacities are provided with the minimum evaporator pressure assumed to be 8 psi lower than the evaporator pressure at design load for the 0 – 50 psig adjustment range product, and 12 psi lower than the evaporator pressure for the 30 – 100 psig adjustment range product. The difference between the design evaporator pressure and the minimum evaporator pressure is referred to as the allowable evaporator pressure change. Therefore, for an ORI-6 0/50 rated for a 40°F R22 evaporator, the nominal capacity would allow the evaporator pressure to drop from the design 68.5 psig to the minimum evaporator pressure of 60.5 psig or a minimum evaporator temperature of approximately 34°F. Refer to Table 3 for capacity multipliers for other allowable pressure changes.

Table 3

ALLOWABLE EVAPORATOR PRESSURE CHANGE – psi		2	4	6	8	10	12	14
CORRECTION FACTOR	ORIT-6, 10-0/50	.3	.6	.8	1.0	1.2	1.3	1.4
	ORIT-6, 10-30/100	—	.2	.6	.7	.9	1.0	1.1

It is considered acceptable to size most single evaporator systems with a 2 psi available pressure drop across the direct acting ORIT valves. This is not to be confused with the allowable evaporator pressure change. This is the pressure drop across the valve when open at the rated condition with the specified amount of refrigerant flowing through the valve.

Example: Select a direct acting ORIT for a R404A single evaporator refrigeration system with a design evaporator temperature of 20°F, a design capacity of 1.4 tons, a minimum allowable evaporator temperature of 14°F, and an available pressure drop of 2 psi.

1. From the capacity table on Page 13 the ORIT-10 is capable of providing 2.29 tons at the design evaporator temperature and available pressure drop.
2. From the capacity table on Page 13 the saturation pressure at the design evaporator is 55.7 psig. This application will require a 30 – 100 psig adjustment range valve, and the minimum evaporator pressure for the nominal capacity selected in step 1 will be 44 psig (10°F) or 12 psi lower. Since the specified minimum allowable evaporator temperature is 14°F (48 psig) a correction factor will have to be used to the nominal capacity to check the selection. The allowable evaporator pressure change is approximately 8 psi (56 – 48) so the resulting capacity is 1.6 tons (2.29 x .7). The ORIT-10 is the proper selection.

#### Pilot Operated EPR Selection:

As previously described, pilot operated EPRs have a high gain relationship and steep gradient. As a result they require negligible allowable evaporator pressure change to control from valve setting to full valve stroke. Therefore, pilot operated EPRs are rated for capacity at a full open position, and no correction factors for minimum evaporator temperatures are necessary.

Example: Select a pilot operated EPR for a 20°F R22 evaporator line up, with a 86,800 Btu/hr load, and piped to a 10°F rack suction header temperature. The refrigerant liquid entering the TEV is 60°F, and the return gas temperature entering the EPR is 45°F (20°F Evaporator + 25°F Superheat = 45°F return gas).

Using quick-pick selection table (Page 14):

1. Locate 10°F “Common Suction” temperature.
2. Locate 20°F “Circuit Temperature”
3. If necessary appropriate correction factor for liquid temperatures from the table on page 14 that vary from the 60°F liquid used for the capacities in this table (see step 3 below).
4. Scan horizontally across capacity columns to select the first model (of desired type) that exceeds the specified capacity in Btu/hr for R22 refrigerant. In this case a SORIT-PI-3 or a SORIT-12 would be selected at 132,100 and 96,700 Btu/hr respectively.

Using conventional capacity tables (Page 13):

1. Determine the “natural” pressure drop across the valve by subtracting the saturated pressure at the 10°F rack suction header temperature from the saturated pressure at the 20°F. In this case the 33 psi header pressure is subtracted from the 43 psi circuit pressure to provide a 10 psi drop across the valve.
2. Converting 86,800 Btu/hr to tons by dividing by 12,000 Btu/ton, yields 7.23 tons.
3. Locate the liquid temperature correction factor for 60°F from the table on page 13, since the capacity table is calculated with a 90°F liquid temperature. Divide the 7.23 ton load from step 2, by the correction factor 1.13. Only 6.51 tons are required.
4. Scan vertically down the 10 psi R22 column and select the first model (of desired type) that exceeds the tons for 20°F evaporator design temperature. As above, the SORIT-12 or SORIT-PI-3 are the appropriate selections.

Sporlan also offers a computer selection program that can provide quick and easy product selections for a wide variety of operating conditions. Contact your Sporlan representative for more information.

**PRODUCT FEATURES, SPECIFICATIONS, & NOMENCLATURE**

**ORIT-6 and ORIT-10**

**Features**

- Direct acting (most economical)
- Adjustable
- Hermetic construction (no gaskets or seals)
- Corrosion resistant construction
- Inlet pressure tap (standard)
- Inlet strainer (standard on ODF models)

**Specifications**

- Maximum Rated Pressure = 400 psig
- Maximum Test Pressure = ORI-6 = 300 psi  
ORI-10 = 200 psi
- Maximum Ambient Temperature = 155°F
- Maximum Fluid Temperature = 240°F
- Minimum Ambient/Fluid Temperature = -40°F
- Factory Setting = See table
- Agency Certifications:

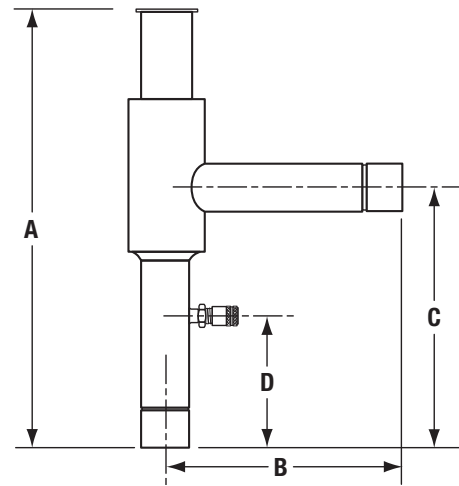

Agency	Product	Guide	File	Country
UL	ORI-6, -10	SFJQ	SA5460	USA
CSA	ORI-6, -10	1223-01	19953	Canada

VALVE TYPE	ADJUSTMENT RANGE psig (Standard BOLD)	CONNECTION Inches Standard Connections BOLD	DIMENSIONS – Inches					WEIGHT – Pounds		INLET STRAINER PART NUMBER
			A	B	C	D	SOCKET	NET	SHIPPING	
ORIT-6	0/50 (Factory set 30)* 30/100 (Factory set 60)*	5/8 ODF Solder	24.77	13.33	16.21	10.31	1.27	1.00	1.25	825-5
		7/8 ODF Solder	24.77	13.33	16.21	10.31	1.91	1.00	1.25	825-7
		1-1/8 ODF Solder	24.77	13.33	16.21	10.31	2.31	1.25	1.50	825-9
		1/2 SAE Flare	16.28	6.81	7.26	2.39	—	1.00	1.25	Not Available
		5/8 SAE Flare	16.21	7.14	7.62	2.69	—	1.00	1.25	
ORIT-10	0/50 (Factory set 30)* 30/100 (Factory set 60)*	7/8 ODF Solder	28.42	14.45	16.51	8.26	1.91	2.50	2.75	825-7
		1-1/8 ODF Solder	28.42	14.45	16.51	8.26	2.31	2.50	2.75	825-9
		1-3/8 ODF Solder	28.42	14.45	16.51	8.26	2.31	2.50	2.75	825-11

\* Manufacturers can specify special settings.

**Materials and Construction Details**

VALVE TYPE	ELEMENT TYPE AND MATERIAL	CONNECTIONS		BODY MATERIAL	SEATING MATERIAL
		TYPE	MATERIAL		
ORIT-6	Bellows – Brass	ODF Solder	Cobre	Brass	Metal-to-Metal
		SAE Flare	Latón		
ORIT-10	Bellows – Brass	ODF Solder	Cobre		

**Valve Nomenclature:**

<b>ORI</b>	<b>T</b>	<b>6</b>	<b>0/50</b>	<b>7/8" ODF</b>
Valve type: Open on Rise of Inlet Pressure	Pressure tap on inlet connection	Port size in eighths of an inch	Adjustment range psig*	Connections ODF Solder or SAE Flare

\* Other pressure ranges are available  
To eliminate delays in shipments, specify complete valve designations.

**PRODUCT FEATURES, SPECIFICATIONS, & NOMENCLATURE**

**(S)ORIT-12, -15, and -20**

**Features**

- High side pilot for improved temperature control and low ΔP operation
- Adjustable settings up to 150 psig
- Optional solenoid stop feature to close valve during system defrost
- Normally open design allows system evacuation without a manual operator

**Specifications**

- Maximum Rated Pressure = 450 psig
- Maximum Test Pressure = 450 psig
- MOPD = 300 psi (SORIT model only)
- Maximum Ambient Temperature = 120°F
- Maximum Fluid Temperature = 240°F
- Minimum Ambient/Fluid Temperature = -40°F
- Factory Setting = See table
- Agency Certifications:

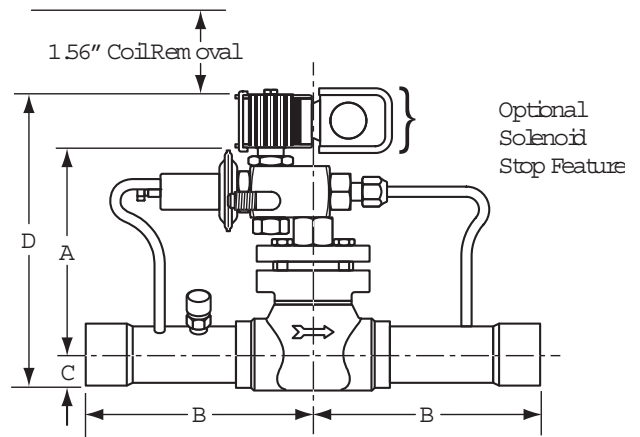
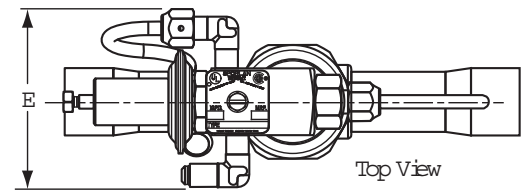

Recognized



Agency	Product	Guide	File	Country
UL	SORIT-12, -15, -20	YI0Z	MH4576	USA
ULc	SORIT-12, -15, -20	YI0Z7	MH4576	Canada
UL	ORIT-12, -15, -20	SFJQ	SA5460	USA
ULc	ORIT-12, -15, -20	SFJQ7	SA5460	Canada

VALVE TYPE	PORT SIZE	ADJUSTMENT RANGE psig (Standard BOLD)	STANDARD COIL RATINGS **MKC-1		CONNECTION ODF SOLDER Inches	DIMENSIONS – Inches				
			Volts/Cycles	Watts		A	B	C	D	E
(S)ORIT-12	19.84	0/100	24/50-60 120/50-60 208-240/50-60 120-208-240/50-60	10	7/8, 1-1/8, 1-3/8	12.67	10.80	1.83	16.51	8.79
(S)ORIT-15	25.4	<b>(Ajuste de Fábrica 30)*</b>			1-3/8	12.47	14.05	2.24	16.31	8.79
(S)ORIT-20	33.34	<b>(Ajuste de Fábrica 120)*</b>			1-5/8, 2-1/8	14.38	14.05	3.66	18.19	8.89

\* Manufacturers can specify special settings.

\*\* Available with junction box or conduit boss at no extra charge. For voltages other than listed consult Bulletin 30-10.

**Valve Nomenclature:**

<b>S</b>	-	<b>ORI</b>	-	<b>T</b>	-	<b>15</b>	-	<b>0/100</b>	-	<b>1-3/8" ODF</b>	-	<b>120/50-60</b>
Solenoid Stop feature (optional)		Valve type: Open on Rise of Inlet pressure		Pressure tap on inlet connection		Valve size		Adjustment range psig*		Connections ODF Solder		Electrical specifications for Solenoid Stop Feature (optional)

\* Other pressure ranges are available

Omission of designation for an optional item indicates a request for a valve less that specific option.

Example: ORIT-15-0/75-1-3/8 ODF; this indicates a valve less the solenoid stop feature.

When ordering a valve with a solenoid stop feature, specify voltage and cycles.

When ordering the solenoid coil assembly only, specify MKC-1 coil, voltage and cycles. Example: MKC-1-120 volts/50-60 cycles.

**PRODUCT FEATURES, SPECIFICATIONS, & NOMENCLATURE**

**(S)ORIT-PI-2, -3, -4 y -5**

**Features**

- Piloted internally (no high side connection required)
- Adjustable settings up to 150 psig
- Optional solenoid stop feature to close valve during system defrost
- Optional electric open feature for "two temperature operation"
- Corrosion resistant construction
- Manual lift stem to allow system evacuation

**Specifications**

- Maximum Rated Pressure = 400 psig
- Maximum Test Pressure = 400 psig
- MOPD = 190 psig (SORIT-PI model only)
- Maximum Ambient Temperature = 120°F
- Maximum Fluid Temperature = 240°F
- Minimum Ambient/Fluid Temperature = -40°F
- Factory Setting = See table
- Agency Certifications:

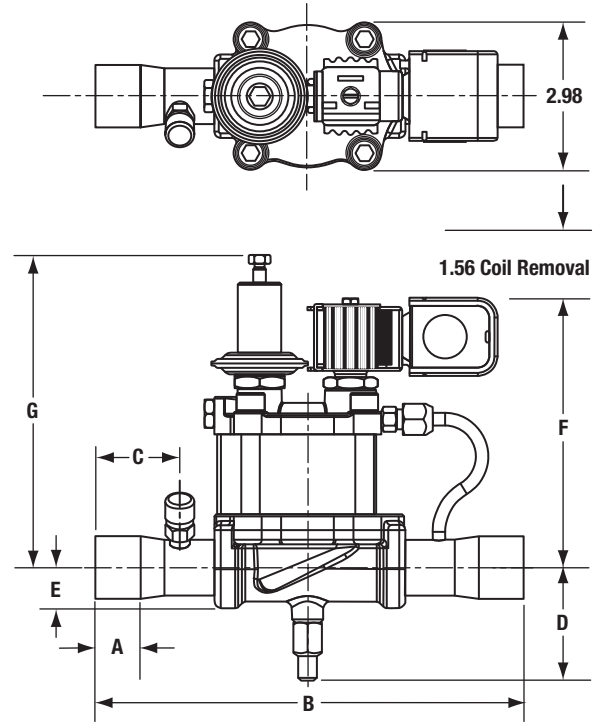

Agency	Product	Guide	File	Country
UL	SORIT-PI-2, -3, -4, -5	YI0Z	MH4576	USA
ULc	SORIT-PI-2, -3, -4, -5	YI0Z7	MH4576	Canada
UL	ORIT-PI-2, -3, -4, -5	SFJQ	SA5460	USA
ULc	ORIT-PI-2, -3, -4, -5	SFJQ7	SA5460	Canada

VALVE TYPE	PORT SIZE	ADJUSTMENT RANGE psig (Standard BOLD)	STANDARD COIL RATINGS **MKC-1		CONNECTION ODF SOLDER Inches	DIMENSIONS – Inches												
			Volts/Cycles	Watts		A	B	C	D	E	F	G						
(S)ORIT-PI-2	12.7	0/100 (Factory set 30)* or 75/150 (Factory set 60)*	24/50-60 120/50-60 208-240/50-60 120-208-240/50-60	10***	5/8	1.27	21.92	4.32	5.79	1.83	13.34	16.00						
					7/8	1.98	21.92	4.32	5.79	1.83	13.34	16.00						
					1-1/8	2.31	21.92	4.32	5.79	1.83	13.34	16.00						
					1-3/8	2.54	27.69	6.45	5.79	1.83	13.34	16.00						
(S)ORIT-PI-3	19.05				0/100 (Factory set 30)* or 75/150 (Factory set 60)*	24/50-60 120/50-60 208-240/50-60 120-208-240/50-60	10***	7/8	1.98	21.92	4.32	5.79	1.83	13.34	16.00			
								1-1/8	2.31	21.92	4.32	5.79	1.83	13.34	16.00			
								1-3/8	2.54	27.69	6.45	5.79	1.83	13.34	16.00			
								1-5/8	2.77	27.69	6.45	5.79	1.83	13.34	16.00			
(S)ORIT-PI-4	25.4							0/100 (Factory set 30)* or 75/150 (Factory set 60)*	24/50-60 120/50-60 208-240/50-60 120-208-240/50-60	10***	1-1/8	2.31	21.92	4.32	5.79	1.83	13.34	16.00
											1-3/8	2.54	27.69	6.45	5.79	1.83	13.34	16.00
											1-5/8	2.77	27.69	6.45	5.79	1.83	13.34	16.00
											2-1/8	3.18	27.69	6.45	5.79	1.83	13.34	16.00
(S)ORIT-PI-5	31.75	0/100 (Factory set 30)* or 75/150 (Factory set 60)*	24/50-60 120/50-60 208-240/50-60 120-208-240/50-60	10***							1-3/8	2.54	27.69	6.45	7.06	3.25	14.45	17.12
											1-5/8	2.77	27.69	6.45	7.06	3.25	14.45	17.12
											2-1/8	3.18	27.69	6.45	7.06	3.25	14.45	17.12

\* Manufacturers can specify special settings.

\*\* Available with junction box or conduit boss at no extra charge. For voltages other than listed consult Bulletin 30-10.

\*\*\* 10 watts/coil if specifying SORIT-PI-xxx, SE would be 20 watts with both coils energized.

**Valve Nomenclature:**

S	ORI	T	- PI	- 2	7	S	E - 0/100	120/50-60	
Solenoid Stop feature (optional)	Basic type: Open on Rise of Inlet pressure	Pressure tap on inlet connection	Piloted internally	Port size in 1/4 of an inch	Fitting size in 1/8 of an inch	Solenoid stop feature (optional)	Electric open feature (optional)	Adjustment range psig *	Electrical specifications for Solenoid Stop Feature(optional)

\* Other pressure ranges are available.

Omission of designation for an optional item indicates a request for a valve less that specific option.

Example: ORIT-PI-411-0/100; this indicates a valve less the solenoid stop feature.

When ordering a valve with a solenoid stop feature, specify voltage and cycles.

When ordering the solenoid coil assembly only, specify MKC-1 coil, voltage and cycles. Example: MKC-1-120 volts/50-60 cycles.

CAPACITY TABLE — Capacity (Tons)

VALVULE TYPE	EVAPORATOR DESIGN TEMPERATURE °F	SATURATION PRESSURE - psig						REFRIGERANT																													
		REFRIGERANT						22						134a						404A & 507																	
		134a		404A		507		0.5		1		2		5		10		20		0.5		1		2		5		10		20							
		70.0	36.0	87.4	91.6	70.0	36.0	87.4	91.6	70.0	36.0	87.4	91.6	70.0	36.0	87.4	91.6	70.0	36.0	87.4	91.6	70.0	36.0	87.4	91.6	70.0	36.0	87.4	91.6	70.0	36.0	87.4	91.6				
ORIT-6 0/50 or 30/100	5	70.0	36.0	87.4	91.6	-	0.94	1.31	1.96	2.53	2.88	-	0.72	0.99	1.41	1.64	1.65	-	0.85	1.18	1.79	2.33	2.74	-	0.62	0.85	1.25	1.52	1.58	-	0.49	0.66	0.93	1.04	1.04		
	-10	36.8	14.4	48.2	51.0	-	0.70	0.97	1.40	1.66	1.69	-	0.51	0.68	0.88	0.90	-	0.62	0.85	1.25	1.52	1.58	-	0.39	0.50	0.58	-	-	-	-	-	-	-				
	-30	20.9	4.6	29.2	31.3	-	0.57	0.77	1.06	1.14	1.14	-	0.39	0.50	0.58	-	-	-	0.37	0.50	0.66	0.67	0.67	-	-	-	-	-	-	-	-	-	-	-			
ORIT-10 0/50 or 30/100	5	70.0	36.0	87.4	91.6	-	2.29	3.23	5.06	7.06	9.70	-	1.78	2.50	3.90	5.37	7.20	-	2.06	2.91	4.57	6.39	8.81	-	1.28	1.80	2.77	3.73	4.62	6.26	-	1.01	1.40	2.13	2.64	3.62	4.81
	-10	36.8	14.4	48.2	51.0	-	1.74	2.45	3.82	5.27	7.10	-	1.28	1.80	2.77	3.73	-	-	1.52	2.14	3.34	4.62	6.26	-	1.01	1.40	2.13	-	-	-	-	-	-	-			
	-30	20.9	4.6	29.2	31.3	-	1.42	2.00	3.09	4.22	5.55	-	1.01	1.40	2.13	-	-	-	0.95	1.32	2.04	2.75	3.53	-	-	-	-	-	-	-	-	-	-	-			
(S)ORIT-12 0/75 or 75/150	5	70.0	36.0	87.4	91.6	2.06	2.91	4.09	6.40	8.87	12.00	1.60	2.26	3.17	4.90	6.68	8.74	1.86	2.62	3.70	5.78	8.04	11.00	1.36	1.92	2.71	4.21	5.77	7.68	1.09	1.53	2.15	3.32	4.49	5.78		
	-10	36.8	14.4	48.2	51.0	1.57	2.21	3.10	4.81	6.57	8.66	1.16	1.62	2.27	3.45	4.56	-	1.36	1.92	2.71	4.21	5.77	7.68	0.91	1.27	1.77	2.63	-	-	-	-	-	-	-			
	-30	20.9	4.6	29.2	31.3	1.28	1.80	2.52	3.88	5.21	6.61	0.91	1.27	1.77	2.63	-	-	0.85	1.20	1.67	2.54	3.37	4.10	0.66	0.93	1.32	2.04	2.75	3.53	-	-	-	-	-	-		
(S)ORIT-15 0/75 or 75/150	5	70.0	36.0	87.4	91.6	3.46	4.88	6.88	10.70	14.90	20.10	2.69	3.79	5.32	8.22	11.20	14.50	3.12	4.41	6.21	9.71	13.50	18.30	2.29	3.23	4.54	7.05	9.67	12.80	1.83	2.57	3.61	5.56	7.50	9.60		
	-10	36.8	14.4	48.2	51.0	2.63	3.71	5.21	8.06	11.00	14.40	1.94	2.73	3.81	5.77	7.59	-	2.29	3.23	4.54	7.05	9.67	12.80	1.53	2.14	2.96	4.39	-	-	-	-	-	-	-			
	-30	20.9	4.6	29.2	31.3	2.15	3.03	4.24	6.50	8.70	10.90	1.53	2.14	2.96	4.39	-	-	1.43	2.01	2.80	4.26	5.61	6.75	1.09	1.53	2.15	3.32	4.49	5.78	-	-	-	-	-	-		
(S)ORIT-20 0/75 or 75/150	5	70.0	36.0	87.4	91.6	7.47	10.50	14.80	23.10	31.80	42.70	5.81	8.18	11.50	17.60	23.70	30.30	6.74	9.51	13.40	20.90	28.90	39.00	4.95	6.97	9.79	15.10	20.60	26.90	3.95	5.55	7.77	11.90	15.90	19.80		
	-10	36.8	14.4	48.2	51.0	5.68	8.00	11.20	17.30	23.40	30.10	4.19	5.87	8.17	12.30	15.90	-	4.95	6.97	9.79	15.10	20.60	26.90	3.29	4.59	6.34	9.27	-	-	-	-	-	-	-			
	-30	20.9	4.6	29.2	31.3	4.64	6.52	9.11	13.90	18.40	22.40	3.29	4.59	6.34	9.27	-	-	3.08	4.33	6.02	9.07	11.70	13.60	2.29	3.23	4.54	7.05	9.67	12.80	-	-	-	-	-	-		
(S)ORIT-PI-2 0/75 or 75/150	5	70.0	36.0	87.4	91.6	-	2.21	3.06	4.71	6.98	9.17	-	1.74	2.41	3.87	5.12	6.24	-	1.97	2.73	4.20	6.35	8.42	-	1.28	1.77	2.66	3.32	-	-	-	-	-	-			
	-10	36.8	14.4	48.2	51.0	-	1.71	2.37	3.81	5.06	6.26	-	1.28	1.77	2.66	3.32	-	-	1.47	2.04	3.14	4.48	5.65	-	1.02	1.39	1.97	-	-	-	-	-	-	-			
	-30	20.9	4.6	29.2	31.3	-	1.41	1.96	3.03	3.91	4.45	-	1.02	1.39	1.97	-	-	-	0.94	1.30	1.97	2.45	2.61	-	-	-	-	-	-	-	-	-	-	-			
(S)ORIT-PI-3 0/75 or 75/150	5	70.0	36.0	87.4	91.6	-	3.92	5.47	8.49	12.30	16.30	-	3.08	4.29	6.79	9.06	11.30	-	3.51	4.90	7.60	11.10	14.90	-	2.25	3.14	4.70	5.96	-	-	-	-	-	-	-		
	-10	36.8	14.4	48.2	51.0	-	3.02	4.21	6.67	8.95	11.30	-	2.25	3.14	4.70	5.96	-	-	2.61	3.64	5.65	7.90	10.10	-	1.78	2.44	3.51	-	-	-	-	-	-	-	-		
	-30	20.9	4.6	29.2	31.3	-	2.49	3.47	5.33	6.96	8.20	-	1.78	2.44	3.51	-	-	-	2.10	2.93	4.58	6.04	7.33	-	-	-	-	-	-	-	-	-	-	-			
(S)ORIT-PI-4 0/75 or 75/150	5	70.0	36.0	87.4	91.6	-	5.90	8.29	13.00	19.10	25.40	-	4.62	6.49	10.60	14.20	17.90	-	5.31	7.46	11.70	17.30	23.30	-	3.36	4.72	7.34	9.41	-	-	-	-	-	-	-		
	-10	36.8	14.4	48.2	51.0	-	4.52	6.35	10.40	14.00	17.80	-	3.36	4.72	7.34	9.41	-	-	3.92	5.51	8.63	12.30	15.90	-	2.66	3.80	5.51	-	-	-	-	-	-	-	-		
	-30	20.9	4.6	29.2	31.3	-	3.71	5.21	8.30	10.90	13.10	-	2.66	3.80	5.51	-	-	-	3.14	4.42	7.11	9.46	11.70	-	-	-	-	-	-	-	-	-	-	-	-		
(S)ORIT-PI-5 0/75 or 75/150	5	70.0	36.0	87.4	91.6	-	7.38	10.40	16.30	22.60	30.70	-	5.73	8.05	12.50	17.00	22.40	-	6.66	9.39	14.70	20.40	27.90	-	4.13	5.77	8.79	11.60	-	-	-	-	-	-	-		
	-10	36.8	14.4	48.2	51.0	-	5.61	7.88	12.20	16.70	22.10	-	4.13	5.77	8.79	11.60	-	-	4.89	6.88	10.70	14.70	19.60	-	3.24	4.49	6.71	-	-	-	-	-	-	-	-		
	-30	20.9	4.6	29.2	31.3	-	4.58	6.42	9.87	13.30	17.00	-	3.24	4.49	6.71	-	-	-	3.89	5.46	8.44	11.40	14.80	-	-	-	-	-	-	-	-	-	-	-	-		

Capacities are calculated in accordance with ASHRAE Standard 158.2, "Methods of testing Capacity of Refrigerant Pressure Regulators". Capacities are based on 90°F Liquid Temperature entering the expansion valve and 25°F superheated vapor entering the compressor.

ORIT-6 and ORIT-10 are rated based on a valve setting 8 psi lower than the Evaporator Design Temperature for the 0/50 psi adjustment range, and 12 psi lower for the 30/100 psi adjustment range.

Refrigerant Liquid Temperature Correction Factors for 90°F Liquid												
	-15	-10	-5	0	5	10	15	20	25	32	38	
R-22	1.35	1.31	1.28	1.24	1.21	1.17	1.13	1.09	1.05	1.00	0.95	
R-134a	1.43	1.39	1.35	1.30	1.26	1.21	1.16	1.12	1.07	1.00	0.94	
R-404A/R-507	1.59	1.53	1.47	1.41	1.35	1.29	1.23	1.16	1.10	1.00	0.92	



QUICK PICK SELECTION TABLES for SUPERMARKET MULTIPLE EVAPORATOR SYSTEMS – Valve Capacity Btuh

COMMON SUCTION °F	CIRCUIT or EVAP. °F	REFRIGERANT 134a										REFRIGERANT 401A														
		(S)ORIT-PI					(S)ORIT					(S)ORIT-PI					(S)ORIT									
		2	3	4	5	20	2	3	4	5	20	2	3	4	5	20	2	3	4	5	20					
-35	-35*	5,100	8,900	13,300	16,100	22,900	6,300	10,600	14,700	17,000	22,900	5,400	9,400	14,100	17,000	22,900	6,700	11,200	15,600	17,000	22,900	6,700	11,200	15,600	17,000	22,900
	-34	7,000	12,300	18,600	22,300	31,700	8,800	14,700	21,300	23,600	31,700	7,400	13,000	19,600	23,600	31,700	9,300	15,600	22,500	23,600	31,700	9,300	15,600	22,500	23,600	31,700
	-33	10,000	17,600	27,300	32,200	45,500	12,700	21,300	26,500	34,100	45,500	10,600	18,600	28,900	34,100	45,500	13,400	22,500	28,000	34,100	45,500	13,400	22,500	28,000	34,100	45,500
	-32	12,400	21,800	33,900	40,300	56,700	15,800	26,500	31,300	42,600	56,700	13,100	23,000	35,800	42,600	56,700	16,700	28,000	33,000	42,600	56,700	16,700	28,000	33,000	42,600	56,700
	-31	14,400	25,400	39,700	47,600	66,500	18,700	31,300	35,700	50,300	66,500	15,200	26,900	42,000	50,300	66,500	19,700	33,000	37,000	50,300	66,500	19,700	33,000	37,000	50,300	66,500
-30	-30	16,200	28,800	45,000	54,400	75,600	21,300	35,700	44,700	62,600	75,600	17,200	30,400	47,600	62,600	75,600	22,500	37,600	41,100	62,600	75,600	22,500	37,600	41,100	62,600	75,600
	-30*	6,400	11,200	16,700	20,200	28,800	8,000	13,400	18,500	21,300	28,800	6,800	11,800	17,600	21,300	28,800	8,400	14,100	19,500	21,300	28,800	8,400	14,100	19,500	21,300	28,800
	-29	8,800	15,500	23,200	28,100	39,900	11,000	18,500	26,700	36,100	39,900	9,300	16,300	24,400	36,100	39,900	11,600	20,000	28,100	36,100	39,900	11,600	20,000	28,100	36,100	39,900
	-28	12,600	22,100	34,300	40,500	57,300	15,900	26,700	33,300	44,700	57,300	13,200	23,200	36,100	44,700	57,300	16,700	28,100	35,000	44,700	57,300	16,700	28,100	35,000	44,700	57,300
	-27	15,500	27,400	42,600	50,600	71,200	19,900	33,300	44,700	62,600	71,200	16,300	28,700	44,700	62,600	71,200	20,900	35,000	41,100	62,600	71,200	20,900	35,000	41,100	62,600	71,200
-25	-26	18,100	31,900	49,800	59,700	83,500	23,400	39,200	44,700	62,600	83,500	19,000	33,600	52,300	62,600	83,500	24,600	41,100	46,900	62,600	83,500	24,600	41,100	46,900	62,600	83,500
	-25	20,400	36,100	56,500	68,100	94,800	26,700	44,700	50,300	71,400	94,800	21,400	38,000	59,300	71,400	94,800	28,000	46,900	51,500	71,400	94,800	28,000	46,900	51,500	71,400	94,800
	-20	30,300	54,700	86,500	107,500	146,200	42,000	70,000	86,400	112,300	146,200	31,800	57,300	90,500	112,300	146,200	43,900	73,100	89,700	112,300	146,200	43,900	73,100	89,700	112,300	146,200
	-25*	8,000	13,900	20,800	25,200	35,900	9,900	16,700	23,100	28,100	35,900	8,400	14,600	21,700	28,100	35,900	10,400	17,400	24,100	28,100	35,900	10,400	17,400	24,100	28,100	35,900
	-24	11,000	19,200	28,800	35,000	49,700	13,800	23,100	33,200	44,600	49,700	11,500	20,100	30,100	44,600	49,700	14,400	24,700	34,700	44,600	49,700	14,400	24,700	34,700	44,600	49,700
-20	-23	15,700	27,500	42,700	50,400	71,300	19,800	33,200	41,400	55,500	71,300	16,400	28,700	44,600	55,500	71,300	20,700	34,700	43,200	55,500	71,300	20,700	34,700	43,200	55,500	71,300
	-22	19,400	34,000	53,000	62,900	88,500	24,700	41,400	48,700	64,600	88,500	20,200	35,500	55,300	64,600	88,500	25,800	43,200	50,800	64,600	88,500	25,800	43,200	50,800	64,600	88,500
	-21	22,500	39,700	62,000	74,100	103,700	29,100	48,700	55,500	77,200	103,700	23,500	41,500	64,600	77,200	103,700	30,300	50,800	57,800	77,200	103,700	30,300	50,800	57,800	77,200	103,700
	-20	25,400	44,900	70,200	84,500	117,800	33,200	55,500	66,400	88,000	117,800	26,500	46,900	73,200	88,000	117,800	34,500	57,800	65,800	88,000	117,800	34,500	57,800	65,800	88,000	117,800
	-15	37,700	67,700	107,000	132,700	180,700	51,900	86,400	103,700	137,700	180,700	39,200	70,500	111,300	137,700	180,700	53,900	89,700	108,200	137,700	180,700	53,900	89,700	108,200	137,700	180,700
-15	-15*	12,000	21,000	31,100	38,100	54,300	15,000	25,200	34,800	44,300	54,300	12,400	21,700	32,100	39,300	54,300	15,500	26,000	35,800	44,300	54,300	15,500	26,000	35,800	44,300	54,300
	-14	16,400	28,800	43,000	52,600	74,800	20,700	34,800	44,600	54,200	74,800	17,000	29,800	44,300	54,200	74,800	21,300	35,800	45,900	54,200	74,800	21,300	35,800	45,900	54,200	74,800
	-13	23,400	41,400	62,200	75,700	107,200	29,800	50,000	62,200	82,000	107,200	24,200	42,700	64,100	82,000	107,200	30,700	51,500	64,000	82,000	107,200	30,700	51,500	64,000	82,000	107,200
	-12	29,100	51,200	79,600	94,400	133,000	37,100	62,200	73,000	95,800	133,000	30,000	52,800	82,000	95,800	133,000	38,200	64,000	75,100	95,800	133,000	38,200	64,000	75,100	95,800	133,000
	-11	33,900	59,700	93,100	111,000	155,700	43,600	73,000	83,000	108,400	155,700	34,900	61,500	95,800	108,400	155,700	44,900	75,100	85,400	108,400	155,700	44,900	75,100	85,400	108,400	155,700
-10	-10	38,200	67,500	105,400	126,400	176,500	49,600	83,000	96,600	130,000	176,500	39,300	69,500	108,400	130,000	176,500	51,000	85,400	94,400	130,000	176,500	51,000	85,400	94,400	130,000	176,500
	-5	56,400	101,200	159,500	196,700	269,000	77,000	128,300	154,400	201,500	269,000	58,000	103,900	163,700	201,500	269,000	78,900	131,500	147,000	201,500	269,000	78,900	131,500	147,000	201,500	269,000
	-10*	14,400	25,300	37,600	46,200	65,800	18,200	30,500	42,100	53,100	65,800	14,800	26,000	38,500	47,400	65,800	18,600	31,300	43,100	53,100	65,800	18,600	31,300	43,100	53,100	65,800
	-9	19,700	34,700	51,800	63,700	90,600	25,100	42,100	50,000	65,300	90,600	20,200	35,500	53,100	65,300	90,600	25,700	43,100	51,500	65,300	90,600	25,700	43,100	51,500	65,300	90,600
	-8	28,000	49,700	75,000	91,600	129,800	36,000	60,500	75,200	98,700	129,800	28,700	51,000	76,700	93,900	129,800	36,900	61,900	77,000	93,900	129,800	36,900	61,900	77,000	93,900	129,800
-5	-7	35,300	62,000	96,400	114,200	161,000	44,900	75,200	88,300	116,900	161,000	36,200	63,500	98,700	116,900	161,000	45,900	77,000	90,300	116,900	161,000	45,900	77,000	90,300	116,900	161,000
	-6	41,000	72,300	112,600	134,200	188,300	52,700	88,300	100,300	137,200	188,300	42,000	74,000	115,200	137,200	188,300	53,900	90,300	102,500	137,200	188,300	53,900	90,300	102,500	137,200	188,300
	-5	46,200	81,600	127,400	152,700	213,400	59,900	100,300	114,400	156,000	213,400	47,300	83,500	130,300	156,000	213,400	61,300	102,500	117,000	156,000	213,400	61,300	102,500	117,000	156,000	213,400
	0	68,200	122,100	192,300	236,600	324,200	92,600	154,400	182,900	241,000	324,200	69,700	124,700	196,200	241,000	324,200	94,400	157,400	182,900	241,000	324,200	94,400	157,400	182,900	241,000	324,200
	-5*	17,200	30,200	45,000	55,500	79,200	21,900	36,700	50,600	63,200	79,200	17,600	30,800	45,900	56,600	79,200	22,300	37,400	51,500	63,200	79,200	22,300	37,400	51,500	63,200	79,200
-4	23,400	41,300	62,000	76,600	108,900	30,100	50,600	72,600	91,200	108,900	23,900	42,200	63,200	78,000	108,900	30,700	51,500	73,900	91,200	108,900	30,700	51,500	73,900	91,200	108,900	
-3	33,300	59,300	89,600	110,000	155,900	43,300	72,600	90,300	112,000	155,900	33,900	60,400	91,200	112,000	155,900	44,100	73,900	99,000	112,000	155,900	44,100	73,900	99,000	112,000	155,900	
-2	42,400	74,400	115,700	137,000	193,300	53,900	90,300	109,300	139,400	193,300	43,200	75,800	117,800	139,400	193,300	54,800	91,900	107,700	139,400	193,300	54,800	91,900	107,700	139,400	193,300	
-1	49,300	86,800	135,100	160,900	226,000	63,200	105,900	120,200	163,600	226,000	50,200	88,300	137,500	163,600	226,000	64,300	107,700	122,200	163,600	226,000	64,300	107,700	122,200	163,600	226,000	
0	55,500	98,000	152,900	182,900	256,000	71,800	120,200	156,000	201,500	256,000	56,500	99,700	155,500	201,500	256,000											



Parker Hannifin Ltd  
Climate and Industrial Controls Group  
Refrigeration and Air Conditioning Europe  
Cortonwood Drive, Brampton  
South Yorkshire S73 0UF  
United Kingdom  
phone +44 (0) 1226 273400  
fax +44 (0) 1226 273401  
[www.parker.com/race](http://www.parker.com/race)

RACE Catalogue 90-20 UK - 06/2010 - Zalsman

