

Rapid-fit Guards

Part no: Small B9163 / Medium B9164 / Large B9165

External Dimensions:

Size	Height	Width	Depth
Small	660mm	1052mm	572mm
Med.	1060mm	1152mm	572mm
Large	1360mm	1152mm	572mm

Internal Dimensions:

Size	Height	Width	Depth
Small	600mm	900mm	500mm
Med.	1000mm	1000mm	500mm
Large	1300mm	1000mm	500mm

Packing Weights:

Small	21kg
Medium	29kg
Large	39kg

Other Features:

- Deters vandalism
- Simple and easy to install tab and slot design allows panels to connect
- Panels: zintec, 70 micron protective zirconium coating, ivory finish
- Panels are removable to allow maintenance of the unit
- Bottom panels available for guard fixed at high level on wall

Assembly:

1. Back panel should be fixed to the wall through the panel in four places.

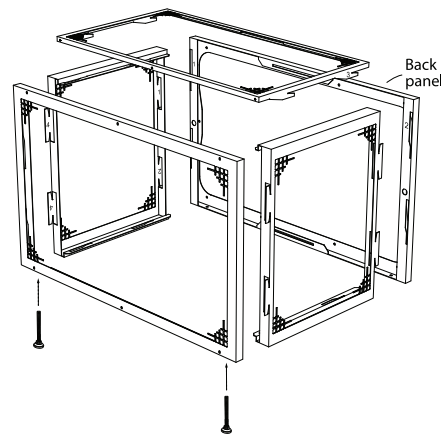

2. All panels fit together with a numbered tab and slot system.

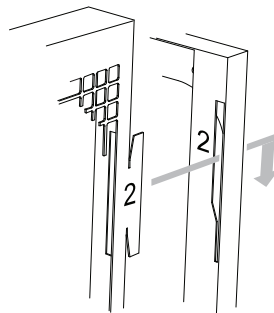

3. Self-adjusting feet are provided to level the front of the unit or to lift the unit off the ground to allow services at ground level.

4. Secure guard using 3 x tamper resistant screws.

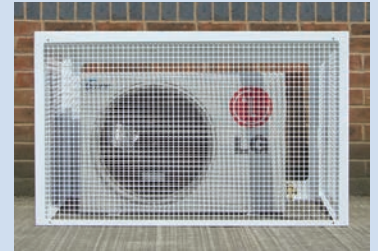
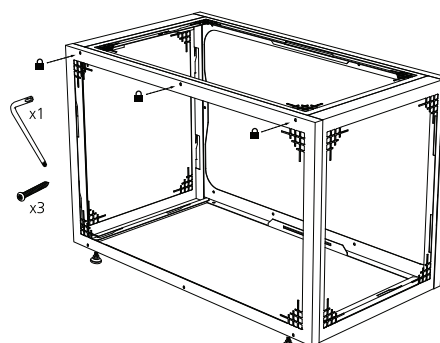

A new range of three Rapid-fit Condensing Unit Guards, to deter vandalism and prevent damage to valuable equipment.

The Rapid-fit Guard framework is a steelwork structure which passes through a 5-part phosphating pretreatment prior to a 70 micron powder coat finish in ivory.

They are quick and easy to install, with a simple numbered tab and slot system. All panels are removable to allow maintenance of the unit. Extra bottom panels are also available for guards fixed at high level on walls.