

CONDENSER MOUNT

Monkeytoe Condenser Wall Mount

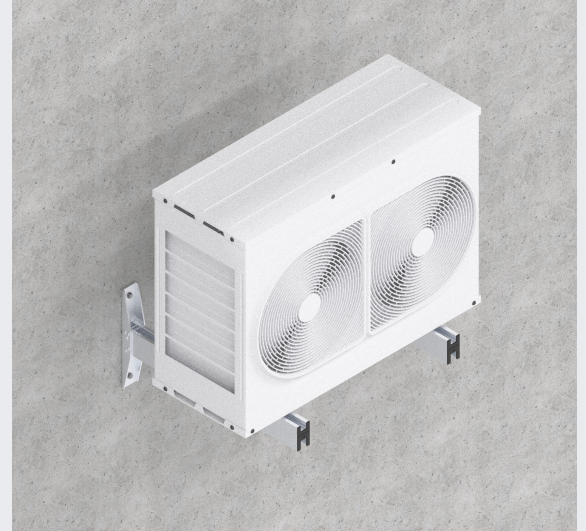

PRODUCT DESCRIPTION

High Tensile, marine grade T6 aluminium wall mount brackets in two standard options, 100kg set & 200kg set – dimensions as per the drawing - Stainless wall fixings and unit mounting fixings can be supplied additionally.

TYPICAL USES / APPLICATIONS

- High tensile marine grade aluminium mounting solutions for condensers in ground mounted and wall mounted applications.
- Ideally suited as a support for a series of Condenser units
- Supports for Fans and flues and other light weight equipment
- Supports for Cable trays, pipes and other services

CHARACTERISTICS / ADVANTAGES

- Quality Heavy Duty Extrusions
- Mount up to 200kg with standard products
- Off the shelf items
- Cost effective
- High tensile marine grade aluminium
- Easy installation with M10 spring studs.
- Strong, lightweight and robust - T6 aluminium construction
- Low maintenance and neat appearance
- Easy installation with M10 spring studs.
- Strong, lightweight and robust

TECHNICAL DATA / MATERIALS

Loading Capacity:

- Light weight Mount - up to 100kg
- Heavy Duty Mount - up to 200kg

Extrusion: varies between sites
Connections: Stainless Steel M10 sliding nuts

TESTS

APPROVALS / STANDARDS

- Structural design action B1
- AS/NZS 1170 Standards Australia / New Zealand
- Aluminium Structures, Part 1: Limit State Design AS/NZS 1664.1 Standards Australia / New Zealand NZS/AS 1657

WARRANTY

- 25 years materials

MAINTENANCE

- Visual inspection for any damage or loose fixings must be done periodically and prior to use.
- No certified maintenance required.
- Basic wear and tear preventative maintenance is recommended, as per manufacturer's specifications and recommendations.

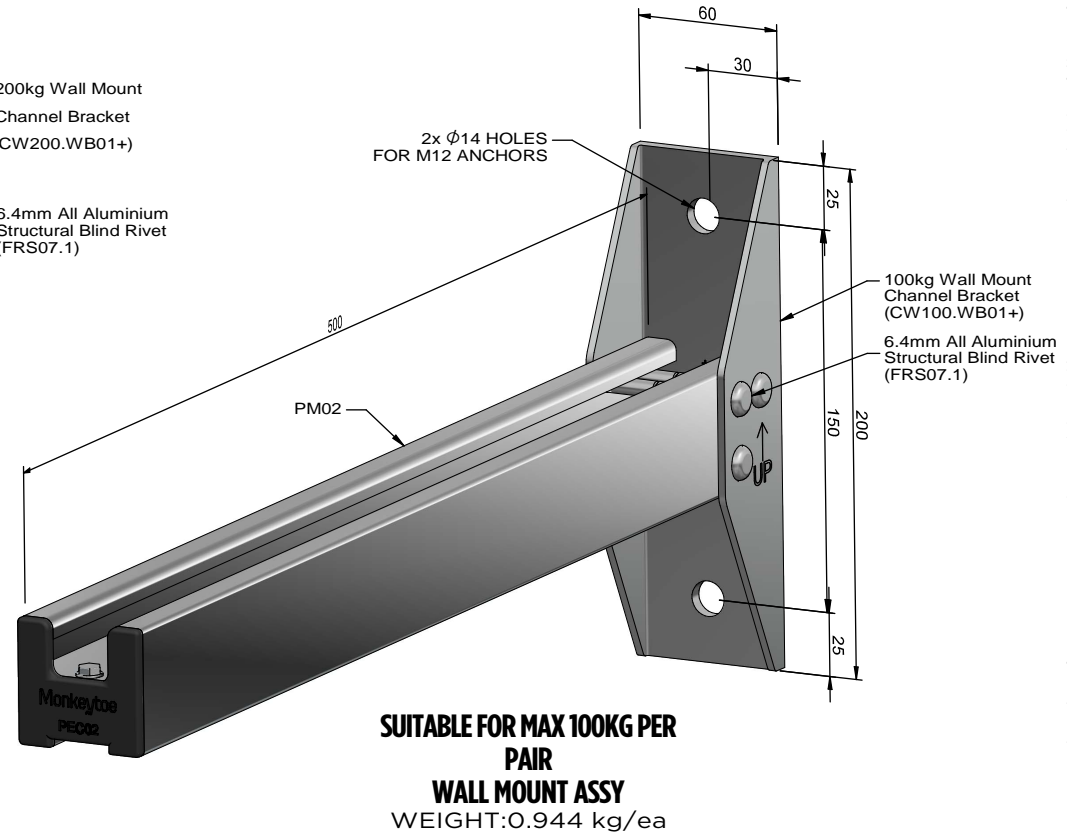
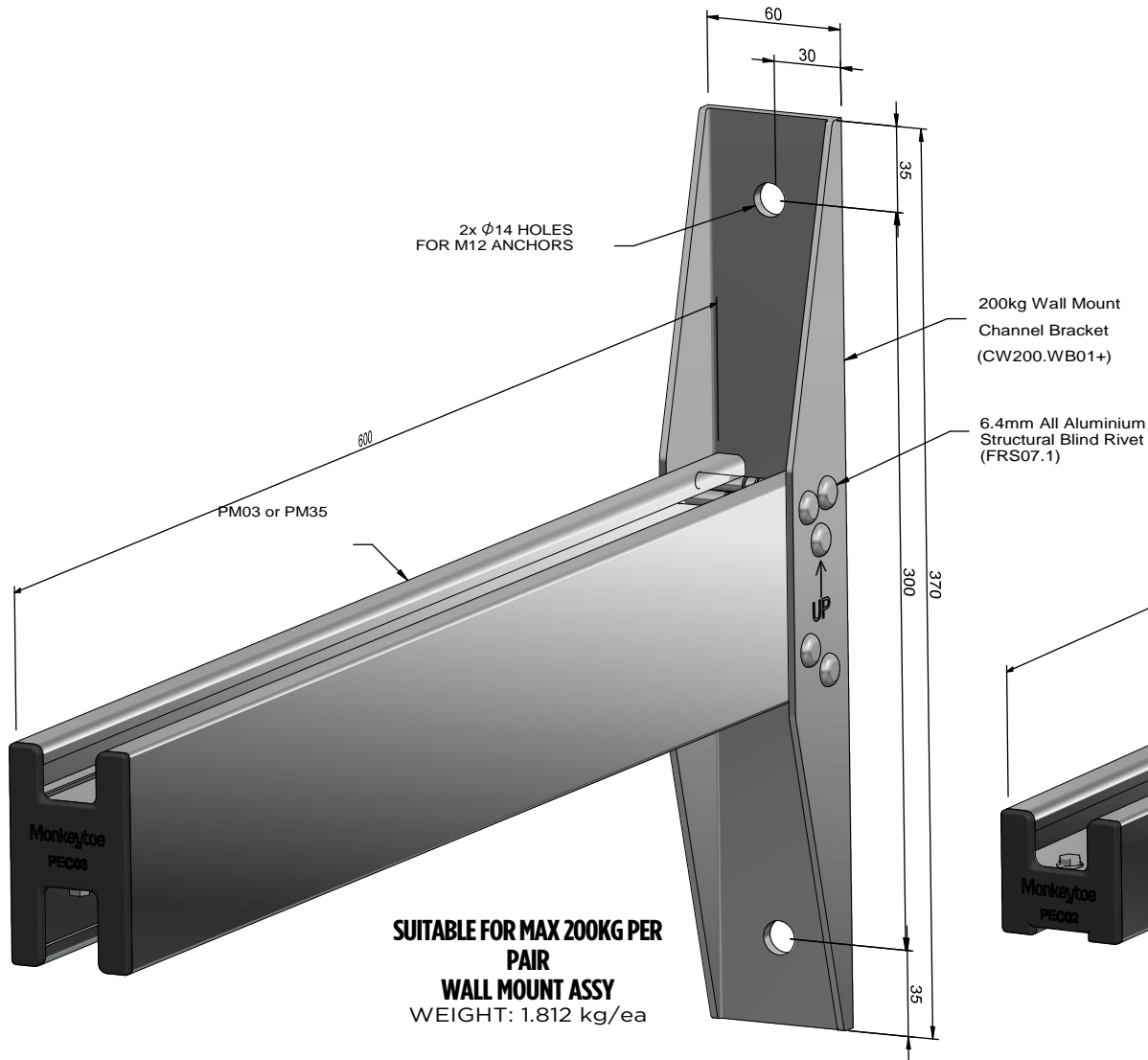

NOTES:

1. FIXINGS NOT INCLUDED
2. RAILS MUST BE INSTALLED IN THE CORRECT ORIENTATION AS PER ETCHED INDICATOR.

This drawing and associated design is the copyright and property of Monkeytoe Ltd. It shall not be used for any purpose or project, without prior written consent other than designated by Monkeytoe Ltd. ©

Monkeytoe

EVERYTHING BETTER
0800 658 637 - www.monkeytoe.co.nz

CONDENSER WALL MOUNTS	
MONKEYTOE	
DWG No: MKT-CW-PS1	10/09/2021
	SHEET 1 OF 1
	A3
DO NOT SCALE	DIMENSIONS IN MILLIMETERS